

FAQ

How can I connect my radio equipment to an IPR100?

The IPR series of Radio over IP (RoIP) interfaces greatly increase the reach and reduce the cost of your radio network by converting analog signals to digital. The IPR100 is compatible with many manufacturers' radios.

This application note explains the basic steps of how to physically connect your radio to an IPR100. If you need to interface to a radio with a 2-wire interface and/or tone signaling please contact Omnitronics for further advice. The detailed product manual can also be made available upon request.

The Connections: 4-Wire and E&M

The radio port on the IPR100 uses a configuration known as 4-Wire + E&M circuit. This circuit has two pairs of connections, which are the '4-Wire' part of the circuit for the audio. The received audio from the radio is one pair and the other pair is for the transmitted audio. These audio pairs are isolated from any power connection.

The other two pairs of connections provide the signaling between the radio and the IPR100. These are the E&M Connections. The 'M' lead, which is a pair of connections, is an output from the IPR100 and is used to drive the Push to Talk (PTT) input for the radio transmitter. Similarly, the 'E' lead is the input to the IPR100 which the radio controls to indicate it has a valid signal. This output from the radio may be called the busy signal, mute signal, Carrier Operated Squelch (COS) or Carrier Operated Relay (COR).

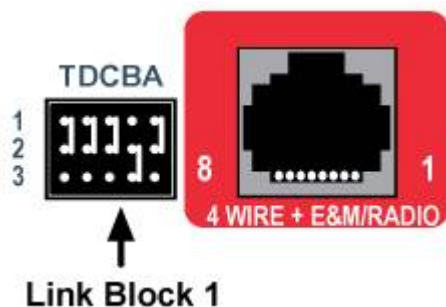

The IPR100 radio connector is labeled "4 WIRE + E&M/RADIO" and is colored red. The pin numbering is shown on the faceplate. Beside the connector is a set of links which are used to configure the E&M signals and for disabling the 600ohm audio input termination.

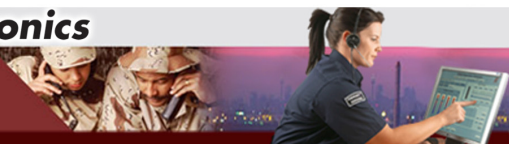



FAQ

How can I connect my radio equipment to an IPR100?

Considerations

Audio Levels

To connect the received and transmit audio we first need to consider the levels that the radio requires for transmission and the level of the received audio.

The radio manufacturer may list these specifications as power in dBm or voltages in either rms or peak to peak values.

Below is a table of the equivalent values for common levels for input and outputs on radios:

dBm (600ohm)	RMS	Peak to Peak
+10	2.5V	6.9V
0	775mV	2.2V
-6	390mV	1.1V
-10	245mV	700mV
-13.5	164mV	463mV
-20	77mV	219mV

The nominal level for the IPR100 is -10dBm but it can accept levels from -20dBm to 0dBm for normal speech. In some tone signaling systems a level of +10dBm is used for a tone burst and provided the input is correctly set to accept 0dBm, this level can be used.

Impedance

Impedance is the load that is driven by the audio signal. It is an important value because it determine how the voltage levels change when the radio and IPR100 are connected together.

The impedance of an *output* is usually considered to be in series or 'in line' with the output signal so that the higher the impedance value the greater the signal that is lost before the signal gets to the output terminals. The impedance of an *input* is usually considered to be across the input so the higher the impedance value the less of a load it is to drive.





FAQ

How can I connect my radio equipment to an IPR100?

The IPR100 is designed to have an impedance of 600 ohms on the input and output and these are the values for which we specify our audio levels.

Alternatively the radio may have a high impedance input or low impedance output. This can cause distortion. To avoid this, do the following:

- If the radio equipment has a *high impedance input*, the level from the IPR100 may need to be decreased by up to 6dB to avoid distortion.
- If it has *low impedance output*, the attenuation on the IPR100 input may need to be increased.

If the radio has *high output impedance*, it will cause the audio voltage to be too low when connected to the 600 ohm input. This can be rectified by removing a link on the IPR100 rear panel which will make the IPR100 a high input impedance, resulting in less load on the radios.

Pre-emphasis and De-emphasis

Due to the nature of FM radio transmissions, the audio frequency spectrum is distorted. To correct for this filters are applied to the audio in the radio. The audio to and from the radio for the IPR100 needs to have a flat frequency response. This audio is usually described as transmit audio and received audio. The transmit audio could be to an external microphone input and the output to a speaker output which will be at different levels to nominal line levels but they will be correctly filtered audio.

Therefore, the 'to the exciter' or 'from the discriminator' connections should not be used as these will not be filtered.

Connecting the Audio Wires

Balanced or Unbalanced Audio?

A balanced line provides audio that is independent of the power supply connection. This type of connection can use transformers or capacitors to provide isolation of the audio signals.



omnitronics



FAQ

How can I connect my radio equipment to an IPR100?

An unbalanced (or single-ended) audio connection uses the power supply return path as the second side of the audio connection. If this type of connection is provided there will be one pin for transmit audio and one pin for received audio. The other side of the audio connection will be a ground or 0V connection. Some radios provide a separate 'analogue' ground which should be used if it is available. If there is no 'analogue' ground use the DC supply 0V or ground.

To connect a Balanced Audio Connection

If the radio has a 4-wire balanced audio connection, connect the 2 radio output wires to the input of the IPR100 and the 2 radio input wires to the IPR100 output.

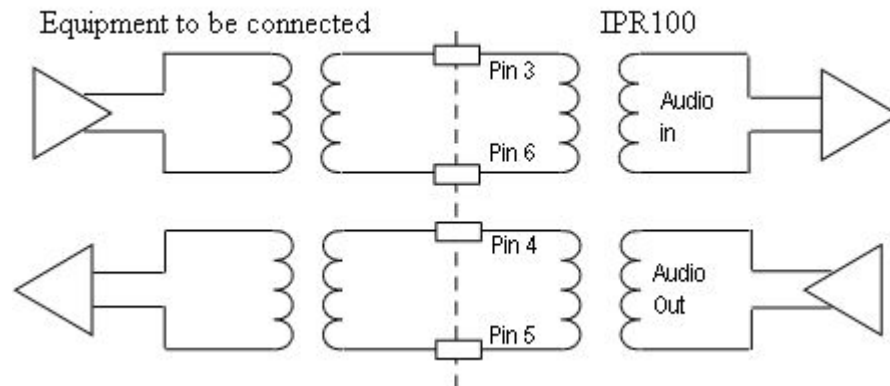

FAQ

How can I connect my radio equipment to an IPR100?

To connect a Unbalanced Audio Connection

If the equipment to be connected has unbalanced inputs and outputs, the required connections are shown below:

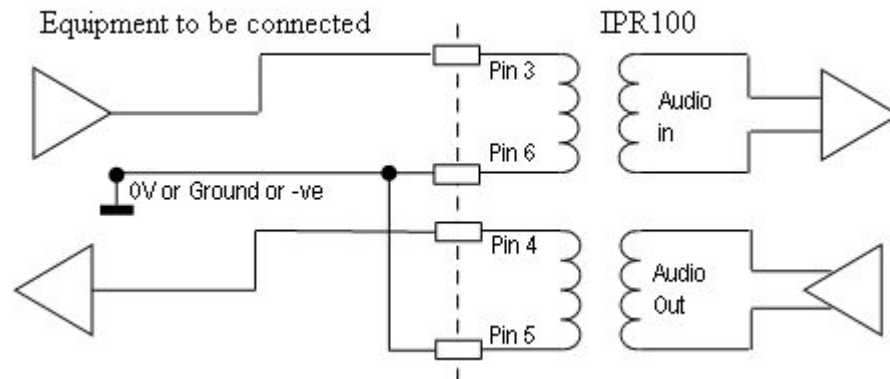

Connecting the Radio to PTT

There are many options for the DC signaling required to turn the transmitter on. The Push To Talk (PTT) signal in most radios is a connection that has an internal pullup resistor to a voltage supply and the signal is turned on by pulling the line to DC ground or 0V.

In the IPR100 there is a set of relay contacts and a set of 2 links which can connect the contacts in different configurations to interface to many different radios.



FAQ

How can I connect my radio equipment to an IPR100?

Diagrams of the different configurations are as below:

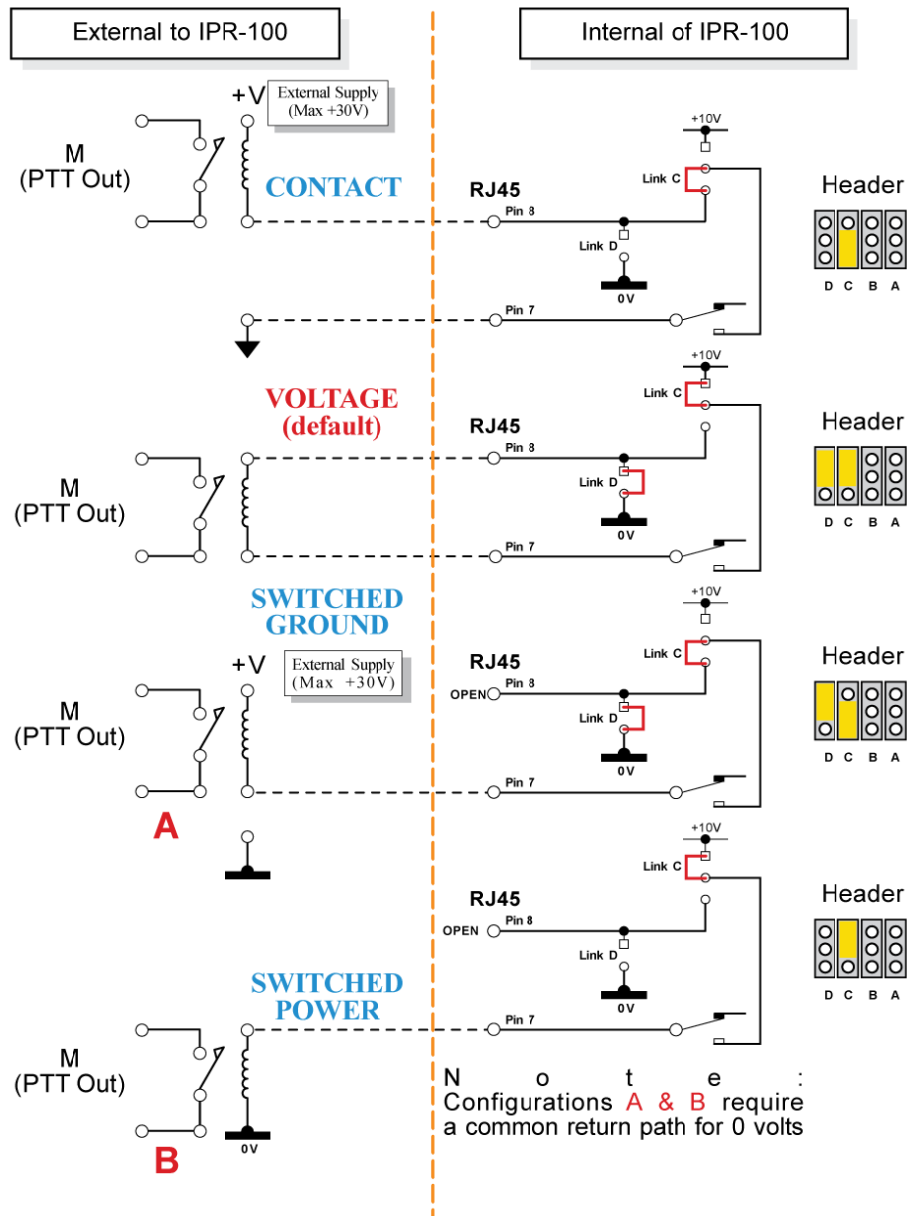



FAQ

How can I connect my radio equipment to an IPR100?

The default setting for the PTT links on an IPR100 are for the unit to supply a voltage out to the radio when the PTT is on. This setting matches the default settings of other Omnitronics equipment for ease of connection.

To change the setting of the PTT relay contacts to be made a contact with no voltage connected, change both link C and D to the lower position (ie pins 2-3). For link D this is the equivalent of leaving the link out which is the picture shown in the previous diagram for the PTT link setting 'Contact'

For a radio that requires the PTT to be pulled to 0V, connect pin 8 of the IPR100 radio port to the radio 0V line (Gnd) and connect pin 7 of the IPR100 radio port to the PTT input.

If the radio does not use a PTT line that is pulled down to become active, connect it using the previous diagram to determine the appropriate connection.

Connecting the Busy Output

This output from the radio indicates that there is a received signal and the IPR should be receiving audio. This signal may be called mute, busy, COS or COR. Some radios will have this signal related to squelch and the level of RF signal at which it is active can be adjusted. The IPR 100 can be setup not to use this input and still operate correctly by using VAD.

For a Relay or Open Collector Transistor

The most common types of output for this signal are either a relay or open collector transistor. Some radios may able describe this output as open drain as they are using a FET instead of a bipolar transistor, but the connection is functionally the same.

Both types of connections can be wired the same way to the IPR100. The links A and B for the Busy input do not have to be changed from the default settings. The connection is as shown in the 'Contact' configuration below.

For a Relay Output with no Voltage

Connect one side of the relay contacts to pin 1 of the IPR100 radio port and the other to pin 2.

For an Open Collector (or Open Drain) Output



omnitronics





FAQ

How can I connect my radio equipment to an IPR100?

Connect the 0V of the radio to pin 1 of the IPR100 radio port and the control line to pin 2.

For an Output that provides Voltage out when the signal is active

Use the 'Voltage' configuration below and change links A and B to suit. The opto-couplers are not polarity sensitive and a voltage from 5V to 30V can be used to activate the input.

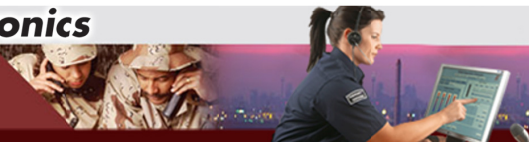
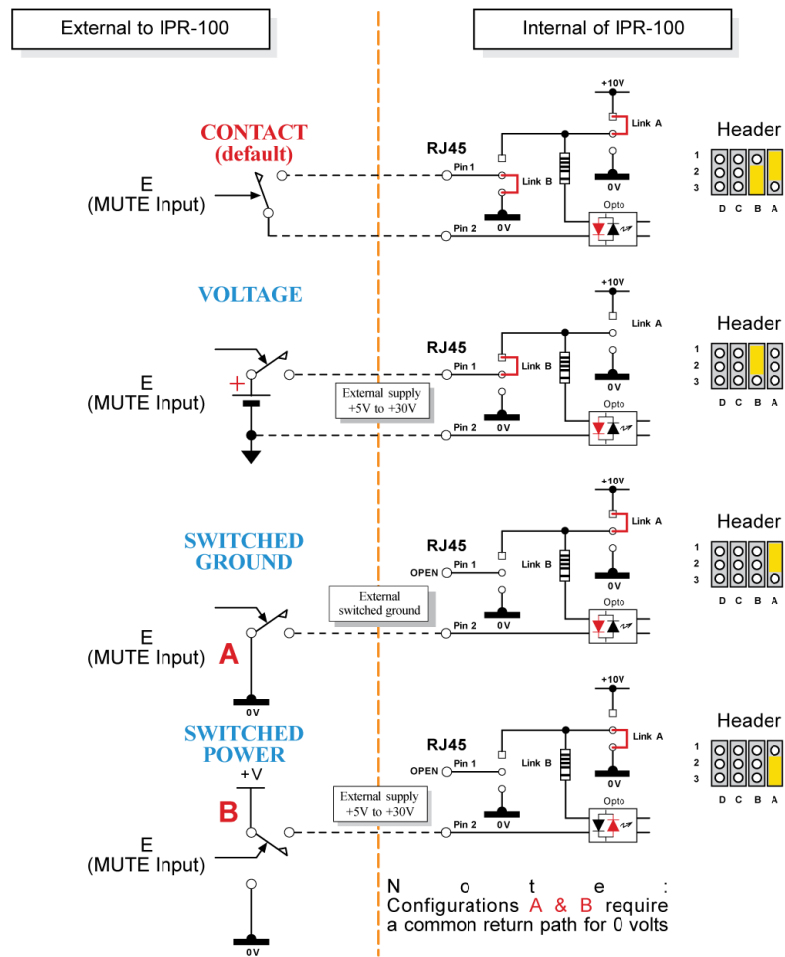



FAQ

How can I connect my radio equipment to an IPR100?

Summary of IPR100 Radio Port Connections

IPR Radio Port Pin	Function	Radio Connector Pin
1	Opto-coupler input for busy signal	
2	Opto-coupler input for busy signal	
3	Input audio to the IPR100 from radio	
4	Output audio from IPR100 to radio	
5	Output audio from IPR100 to radio	
6	Input audio to IPR100 from radio	
7	PTT relay contact	
8	PTT relay contact (this is the best pin to connect to 0V)	



omnitronics

